

HISTORICAL COLLECTION

WORLD WAR II



75MM H.M.C M8 SCOTT

IN U.S. SERVICE - 1942 - 1945
PLACE OF ORIGIN - UNITED STATES
TYPE - SELF-PROPELLED HOWITZER
COMBAT WEIGHT - 15,5T (34,263Lb)
ARMOUR - 13-44MM (.5-1.7")
ARMAMENT - 1x 75MM (2.95") HOWITZER M2/M3,
1x 12,7MM (.50") BROWNING M2HB MG
ENGINE - 2x CADILLAC V8 1G, 110kW (148HP)
ROAD SPEED - 56KM/H (35MPH)
CREW - 4



2279

PAD PRINTED
NO STICKERS

Printed in EU



525  1 

75MM H.M.C M8 SCOTT

SCALE 1:35

1

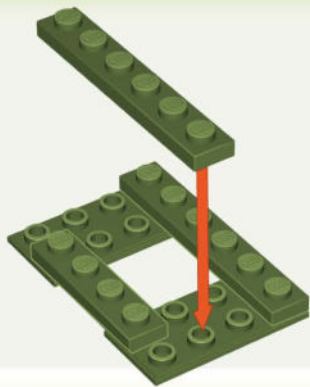

x2



x1



x2

2

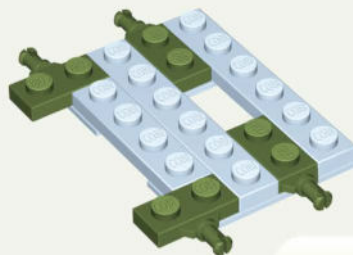

x2



x2

3

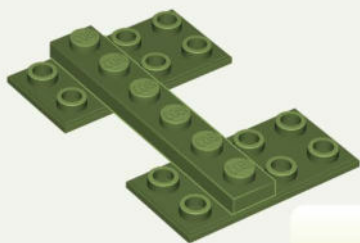

x2



x1

4

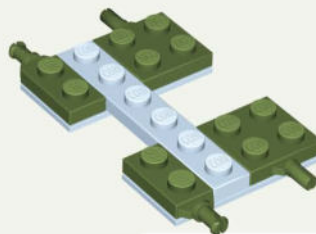

x2



x2

5

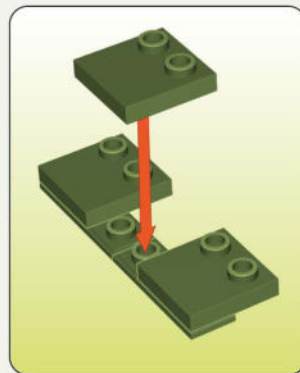
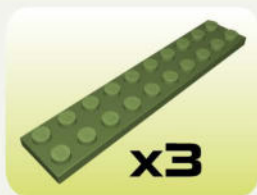
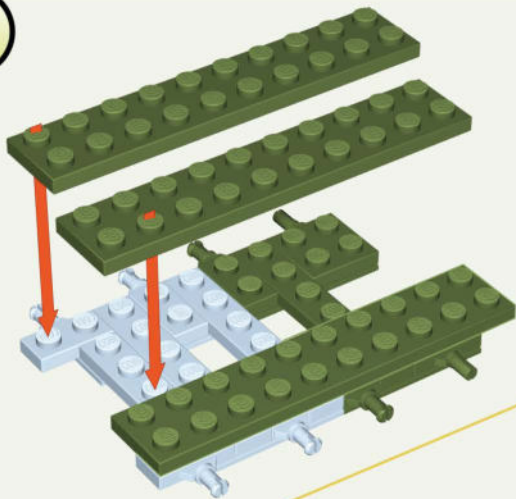

6

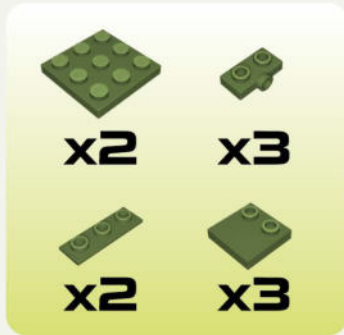
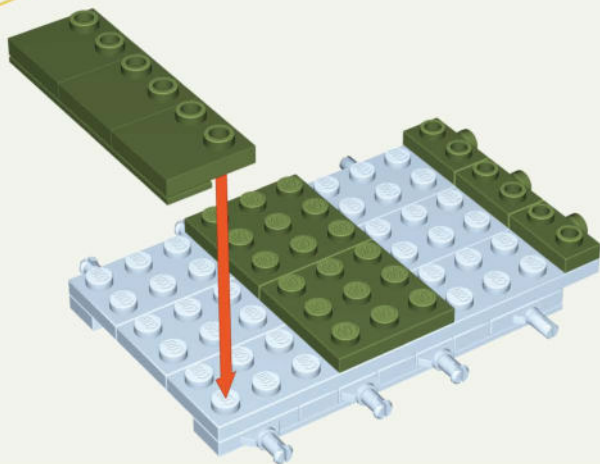

7

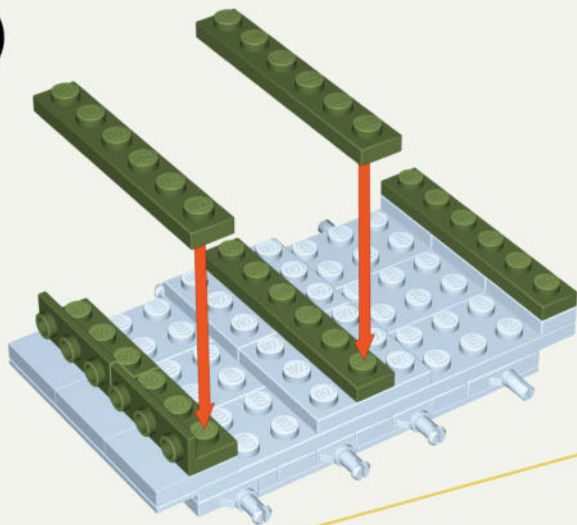

x2



x4

8

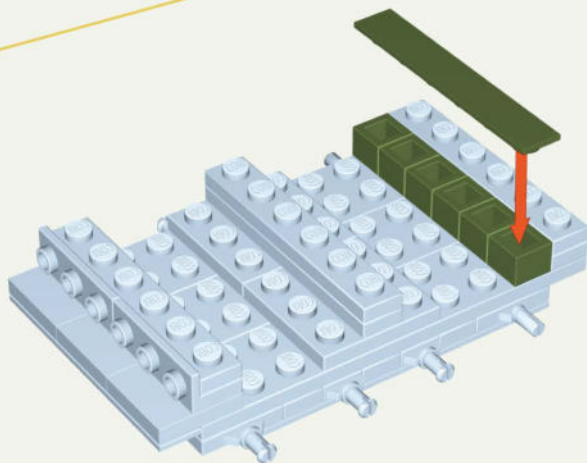







x6

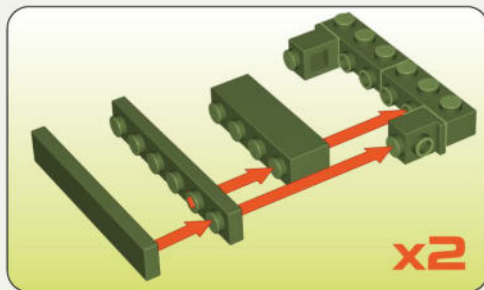
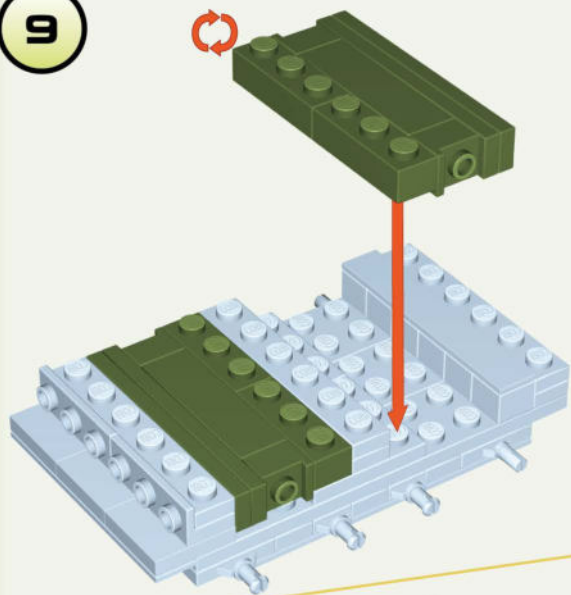

x1

9

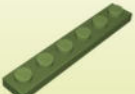

	
x4	x4
	
x2	x2
	
x2	
1:1	

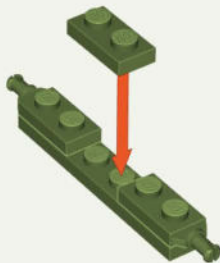

10

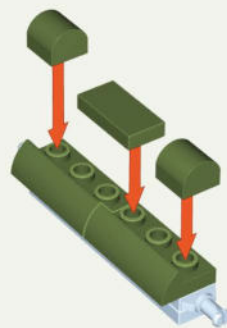

	x1
	x2
	x1

11



	x2
	x2
	x1
1:1	

12

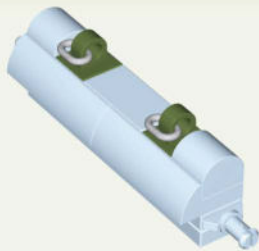

13

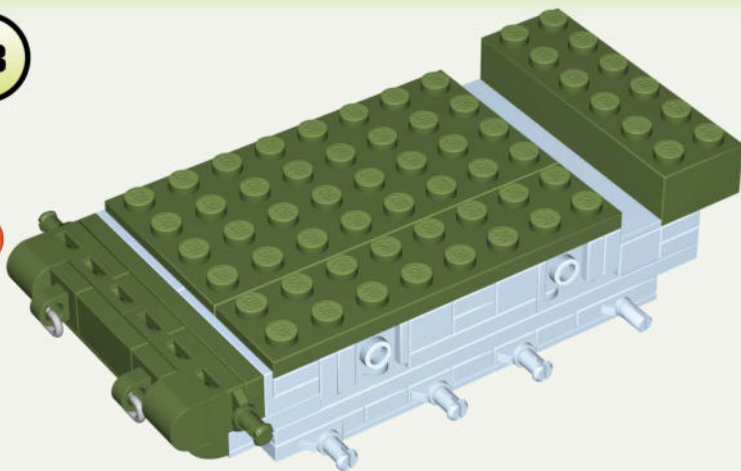

14

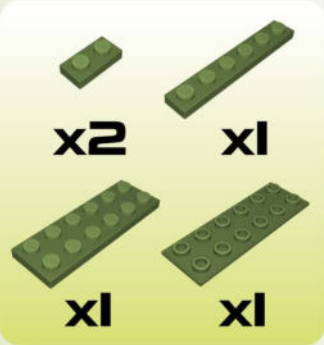
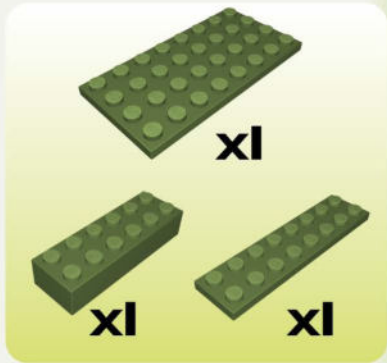
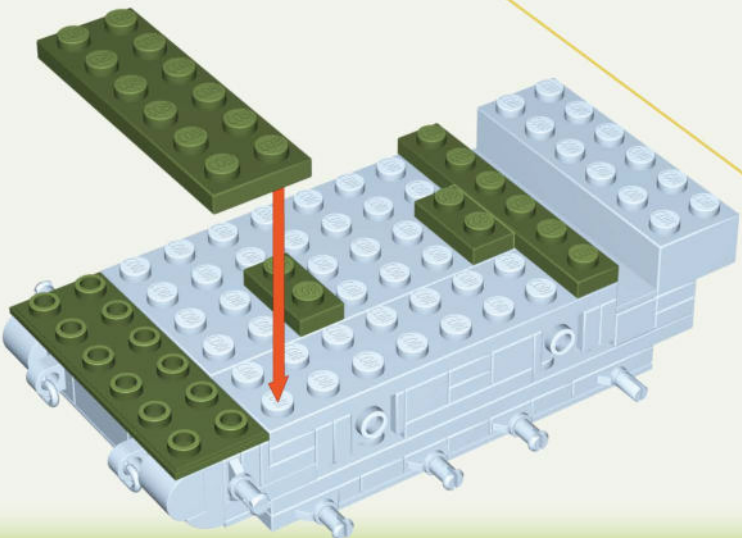

15

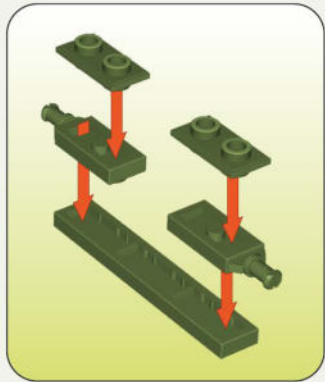
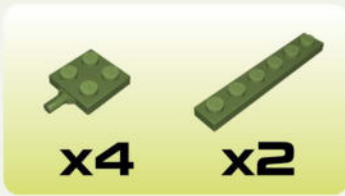
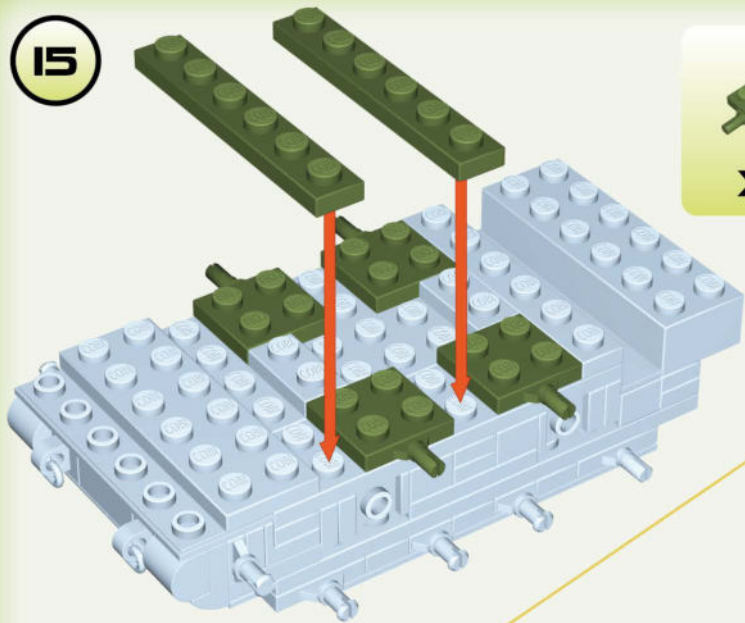

16

1:1

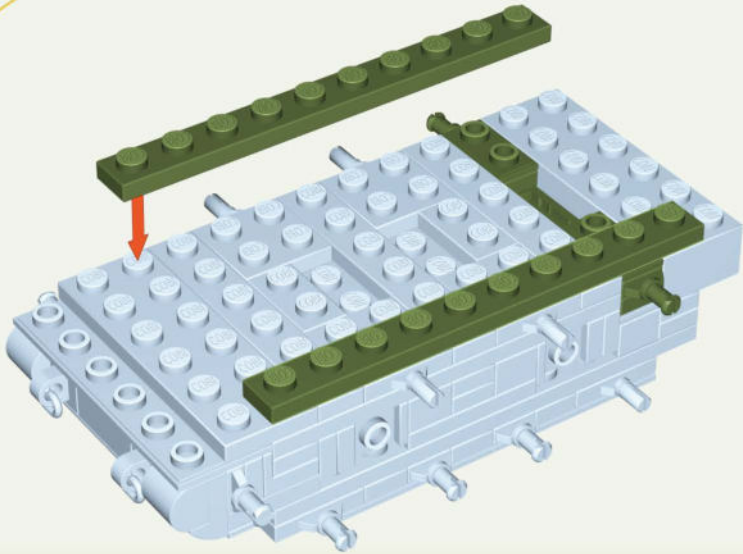
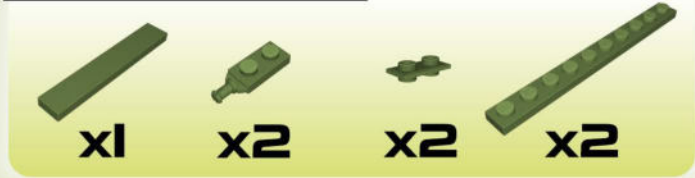

17

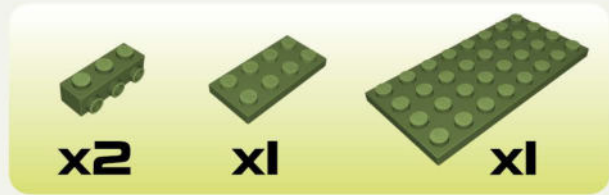
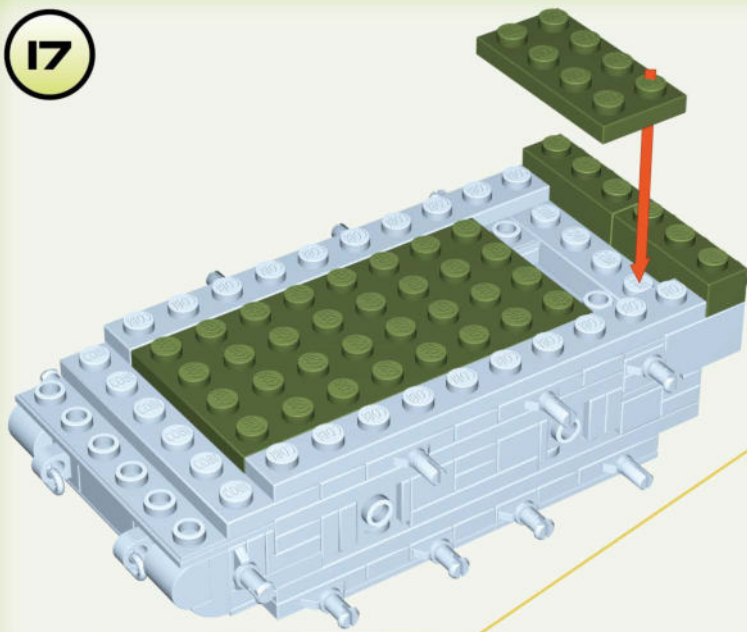

18

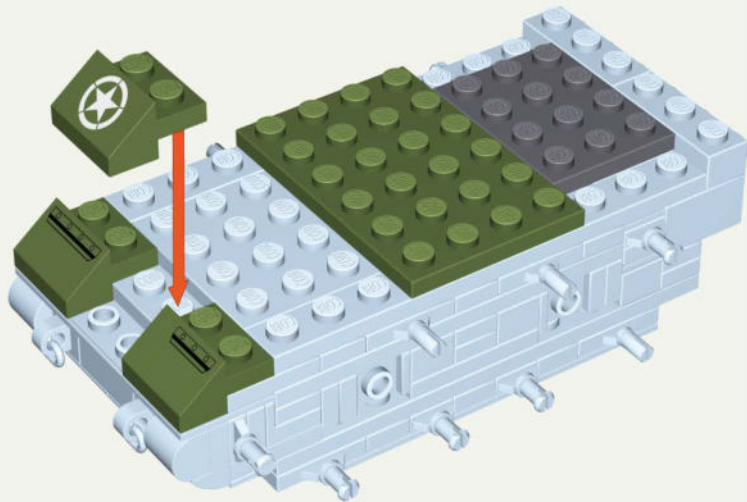
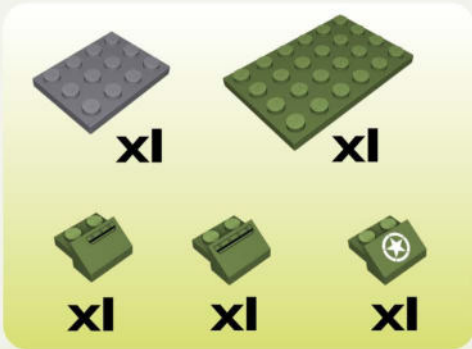

19

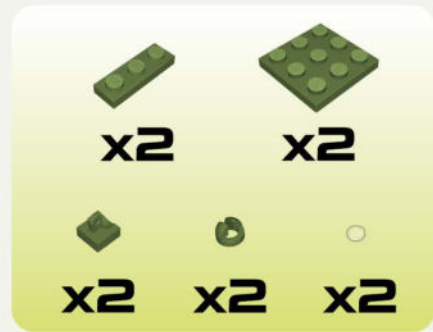
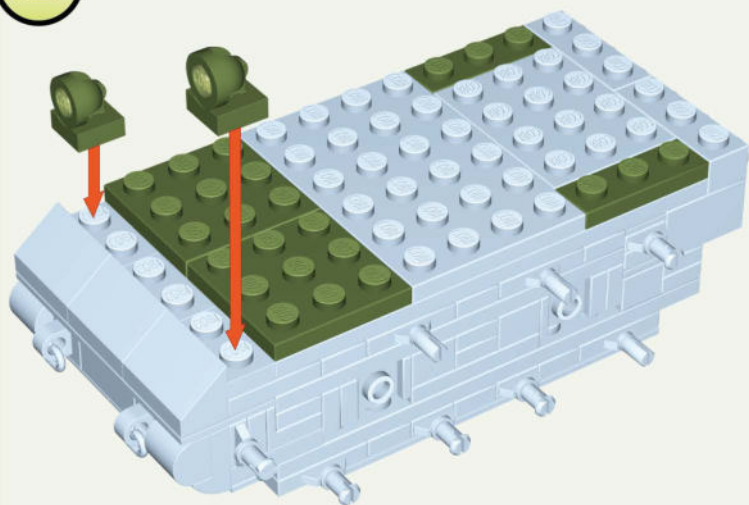

20

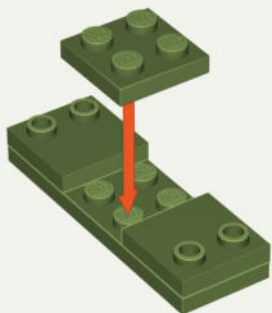

21

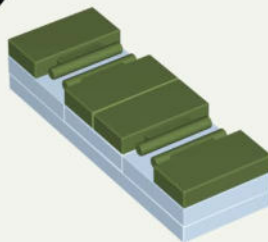

22

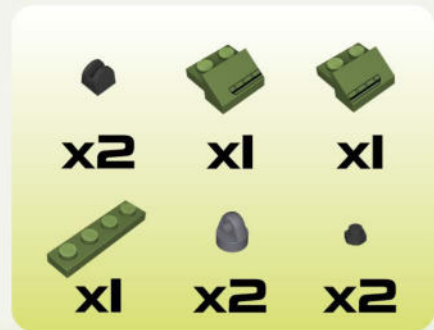
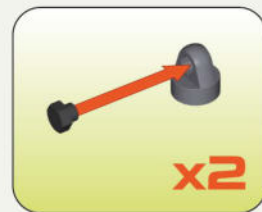
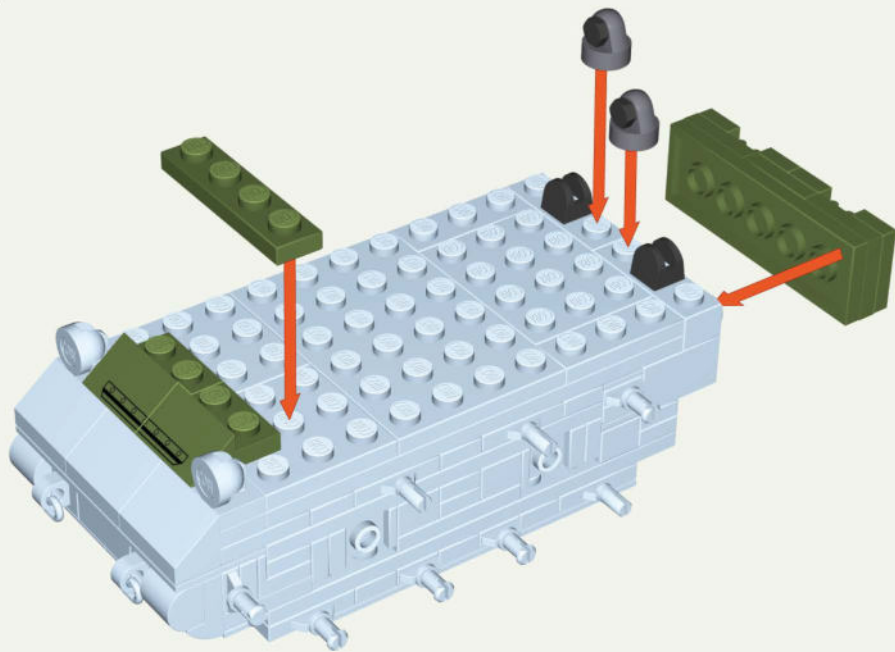

23

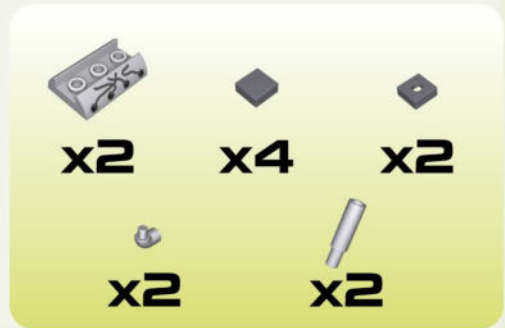
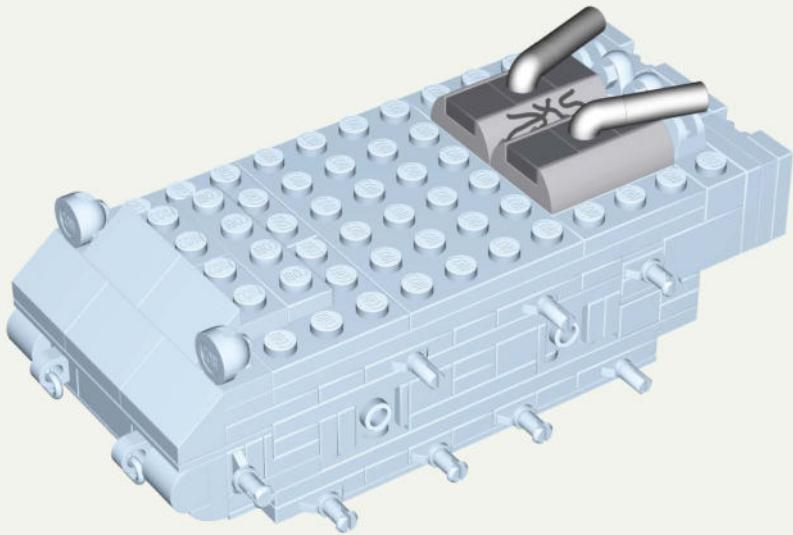
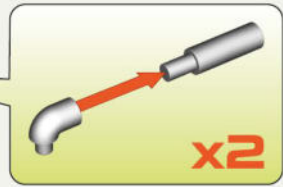
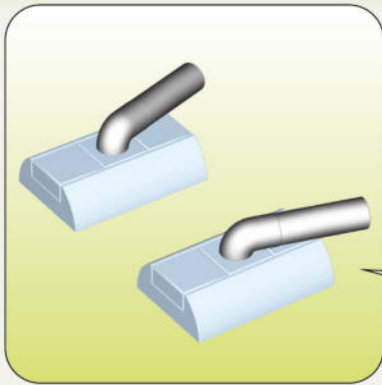
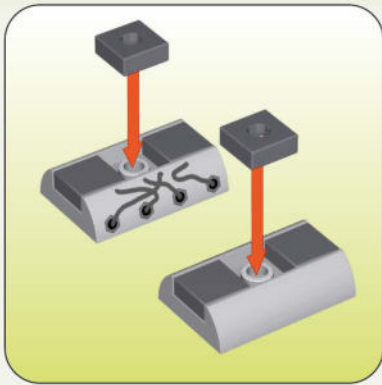

24

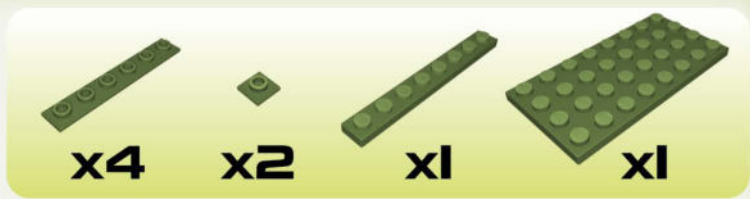
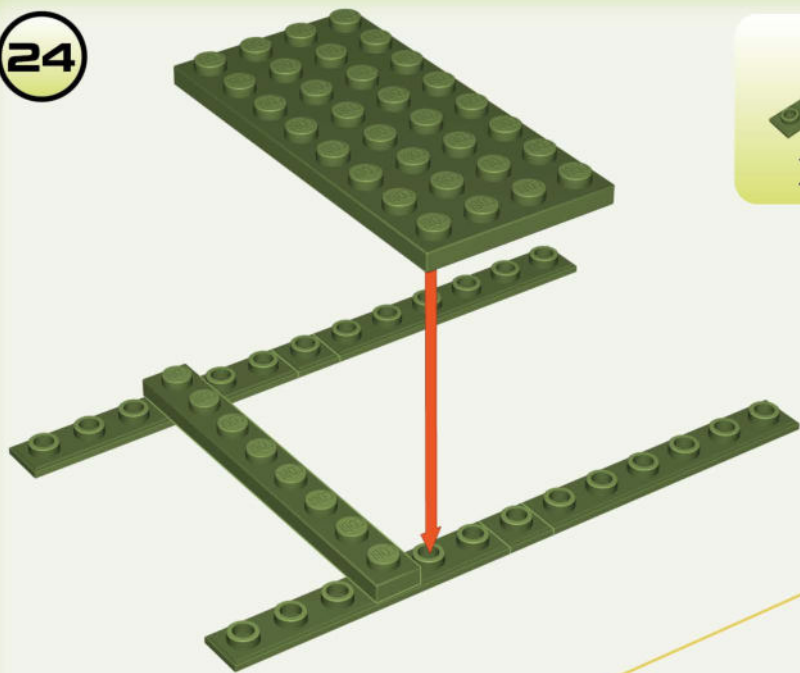

25

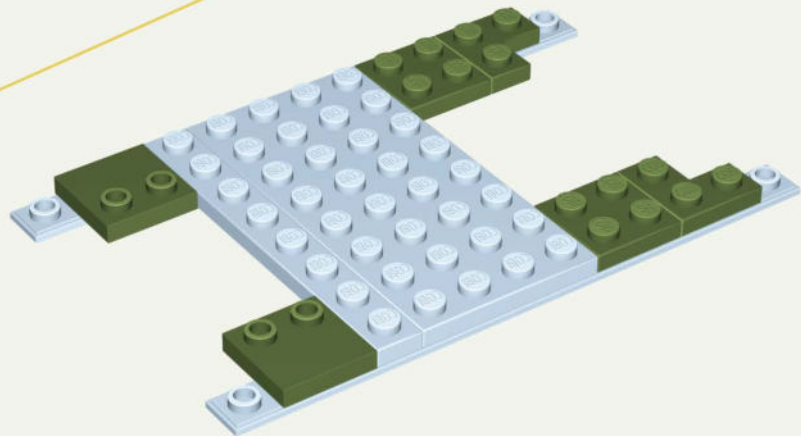

26

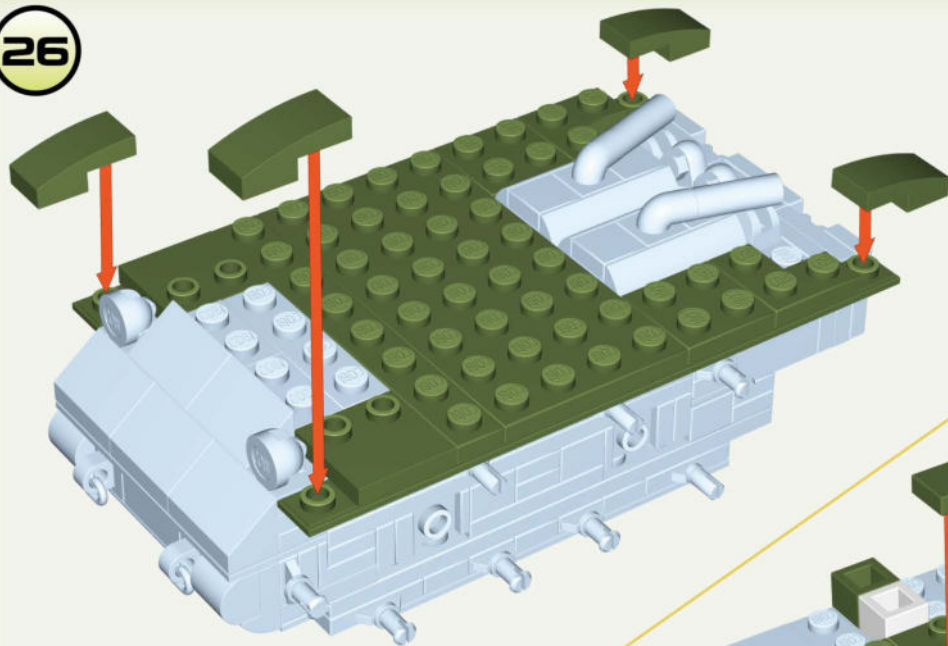

27

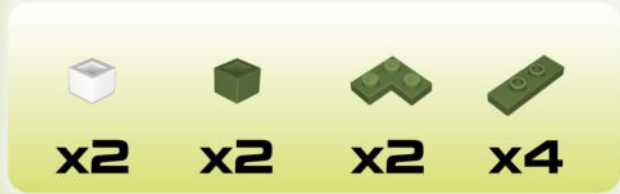
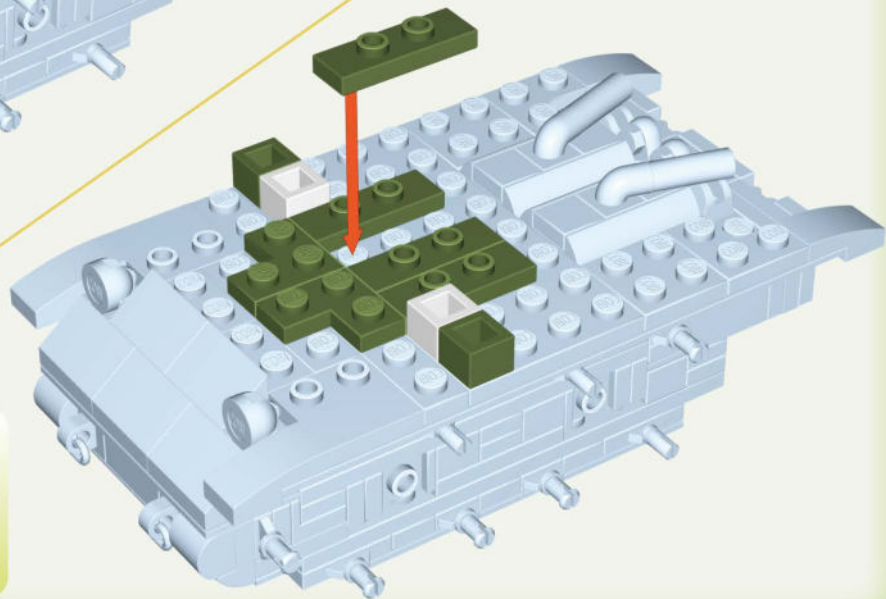

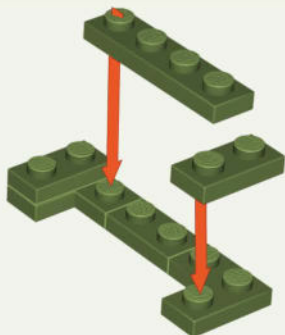

28

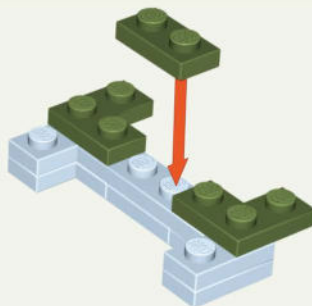

-  x2
-  x3
-  x1

29



-  x1
-  x2

30

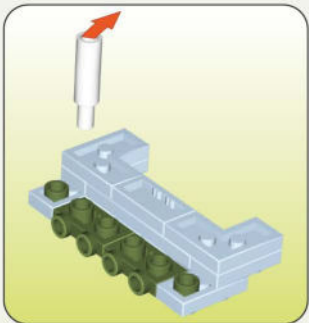
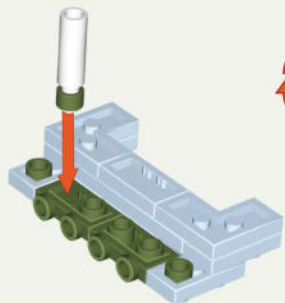

-  x2
-  x6

31

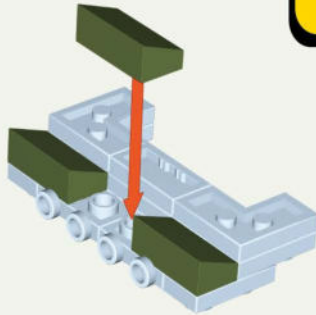
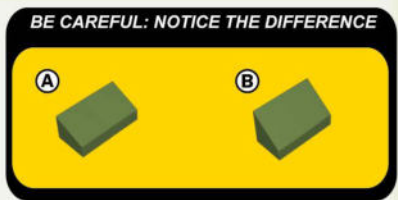

-  x3

32

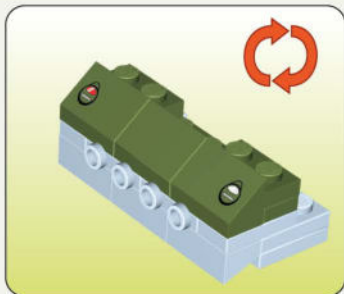
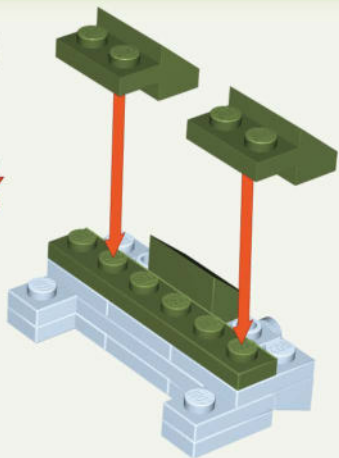

x1



x1



x1



x1

33



x1







x1

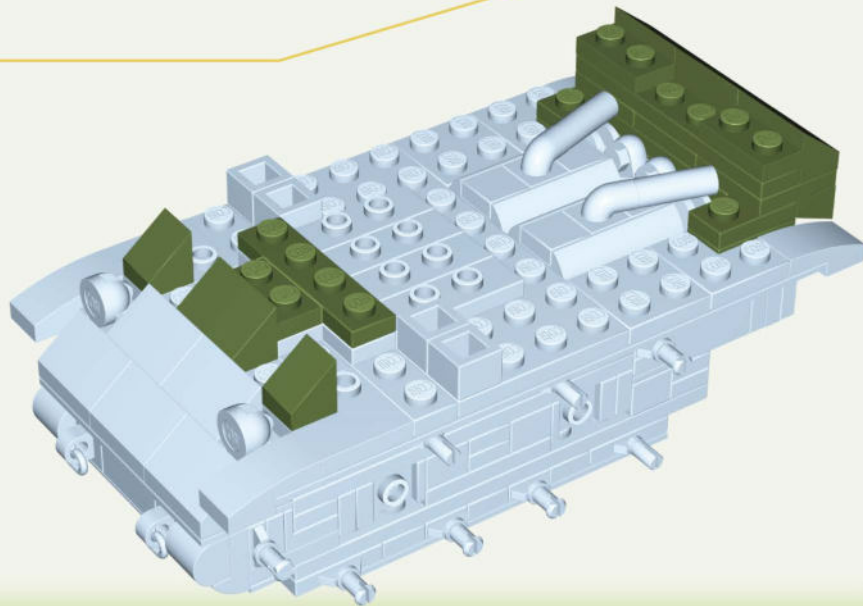

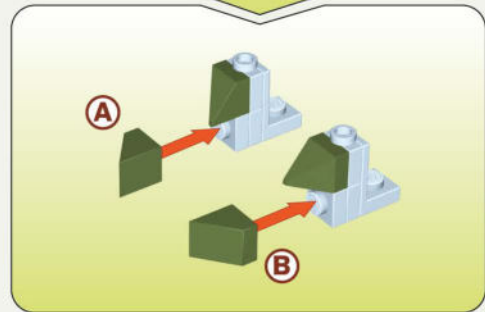
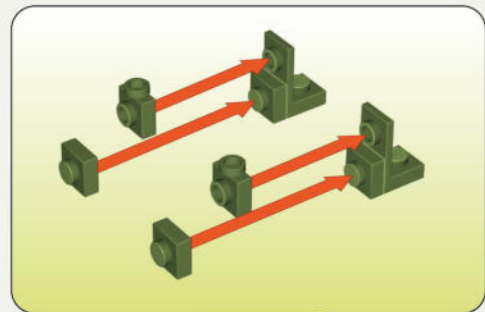
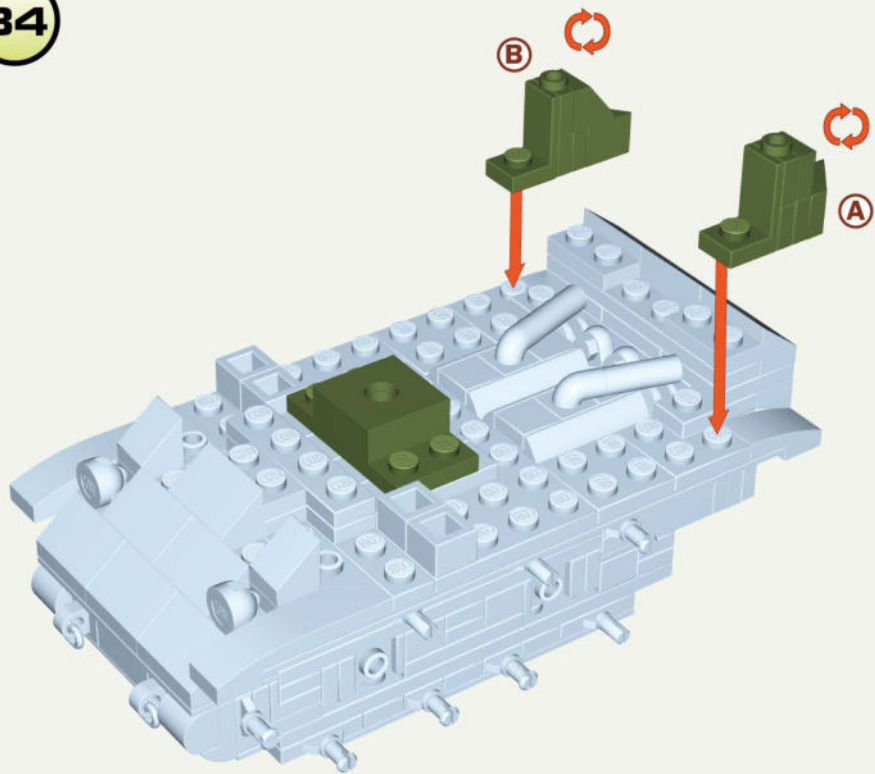
x2





-  x2
-  x4
-  x2
-  x2
-  x2
-  x1

35

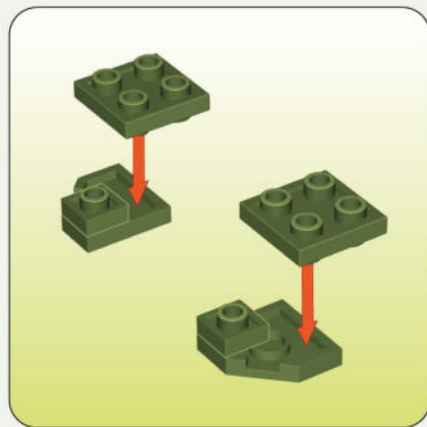
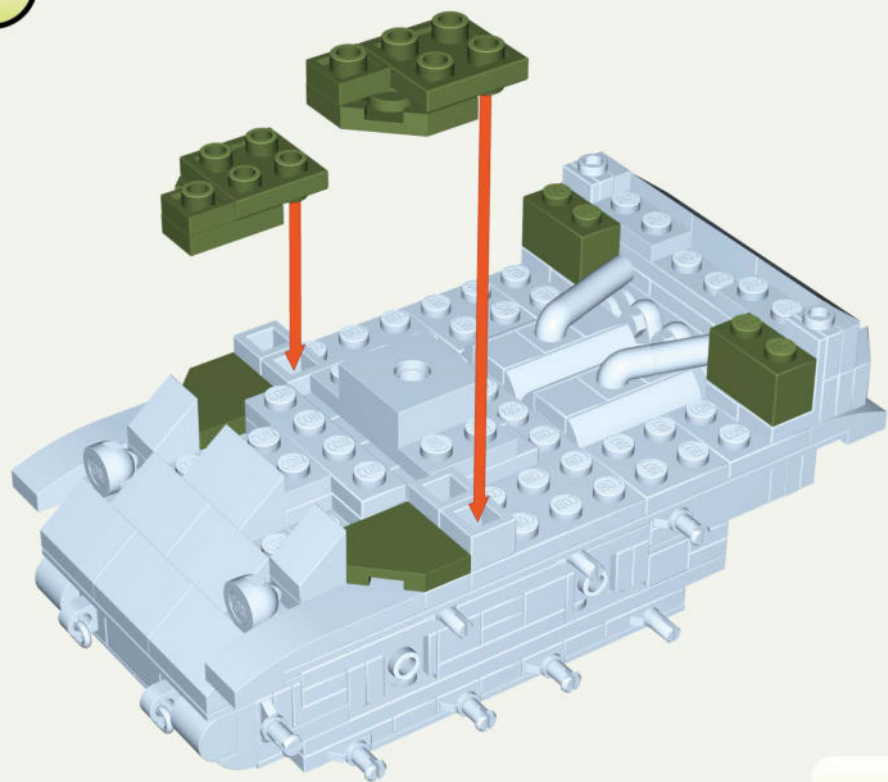

x2



x4



x2



x2

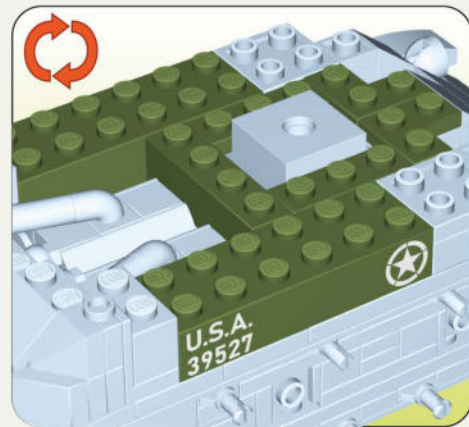
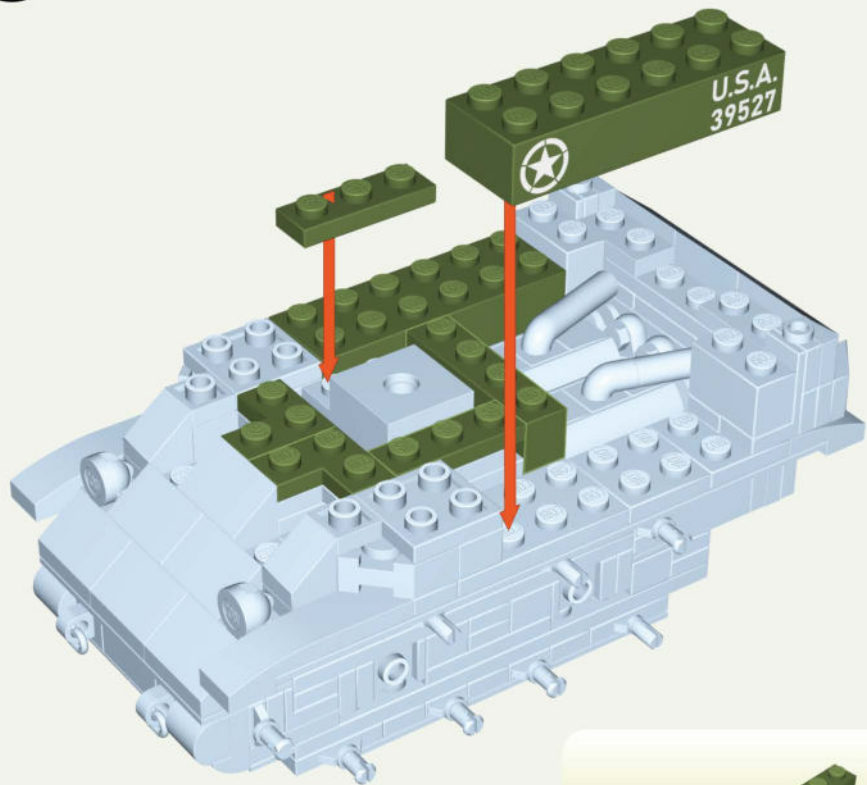

x2



x1



x2



x1



x1

37

1:1

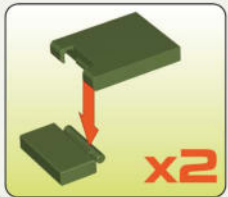
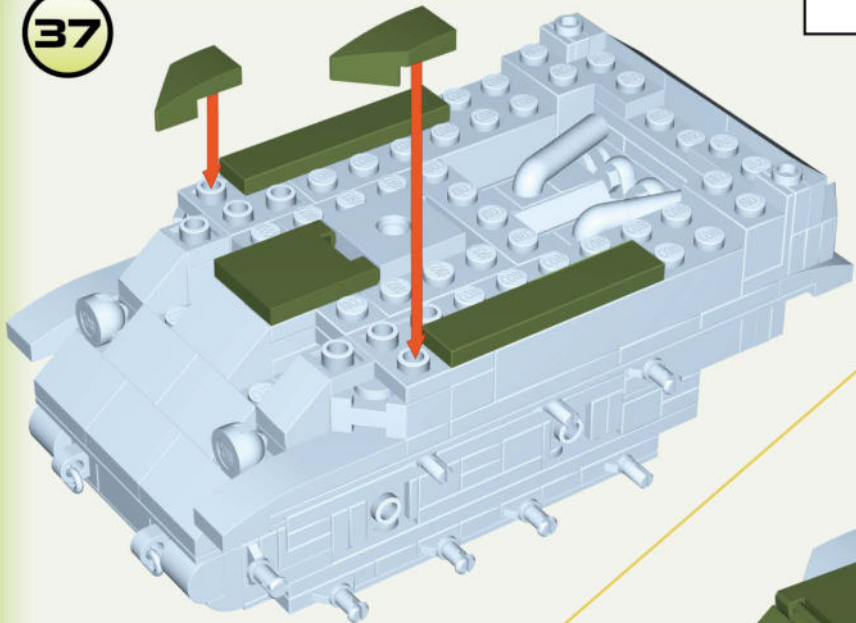

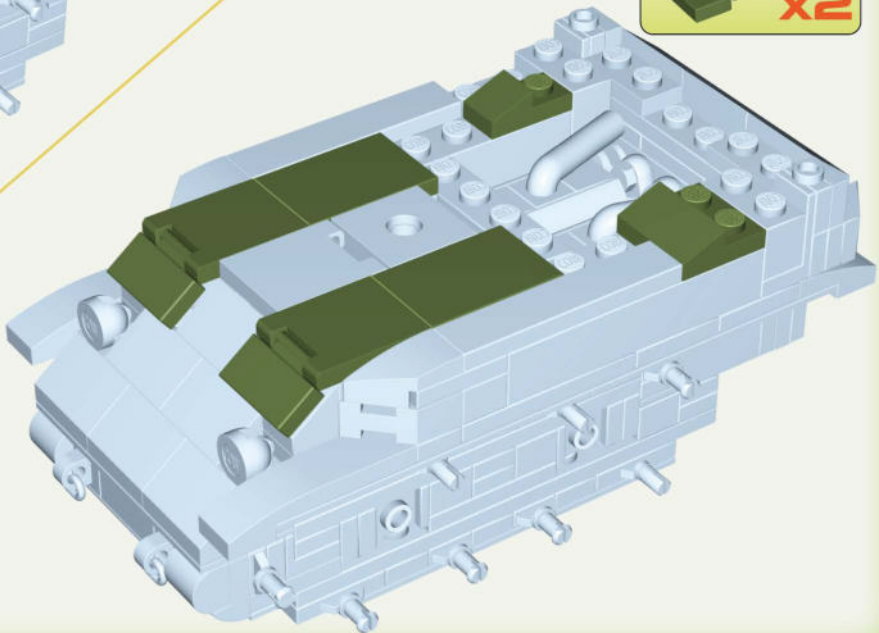
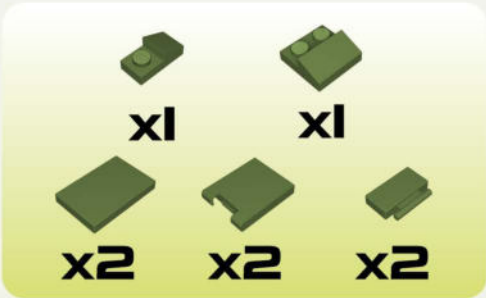

38

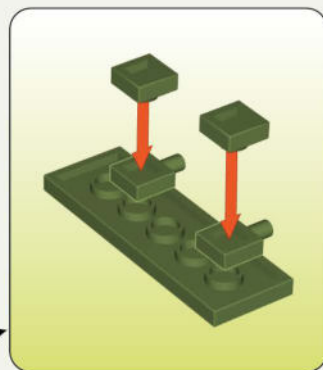
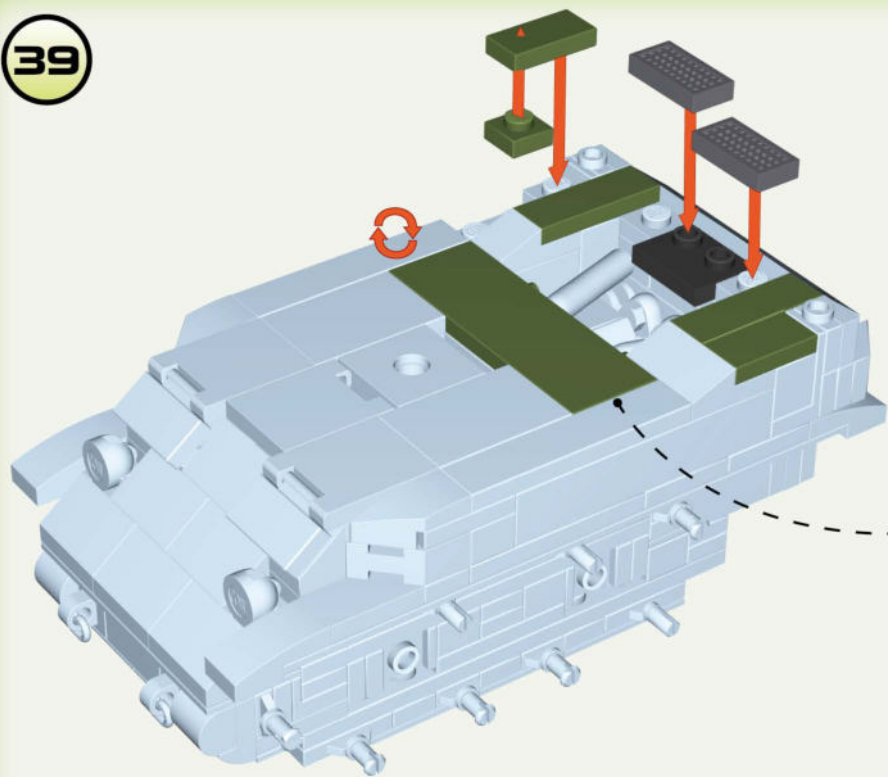

39







- | | | | | | | | |
|--|---|---|---|---|---|---|---|
|  |  |  |  |  |  |  |  |
| x1 | x2 | x2 | x2 | x1 | x1 | x2 | x2 |
- 1:1 1:1

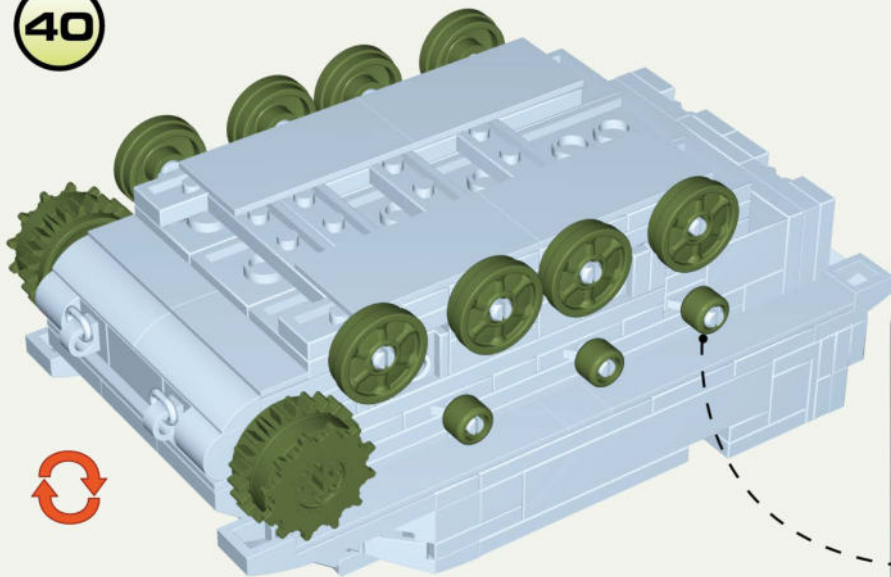

40



- | | |
|---|---|
|  |  |
| x8 | x6 |
|  |  |
| x2 | x2 |

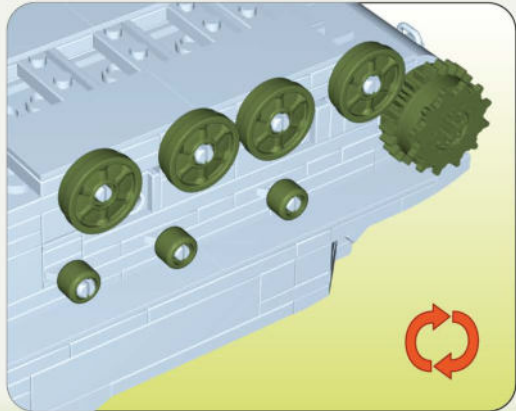
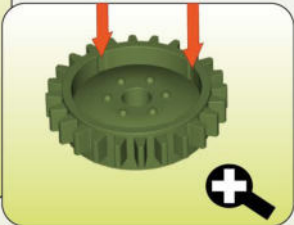
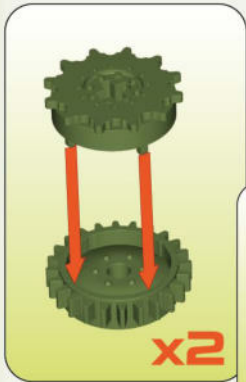
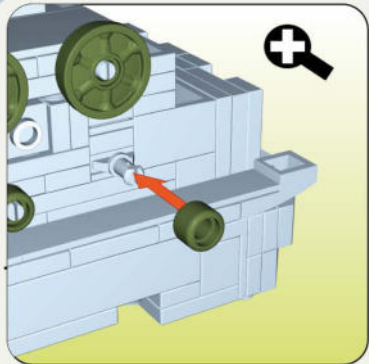

41

1:1



x1



x1



x6



x1









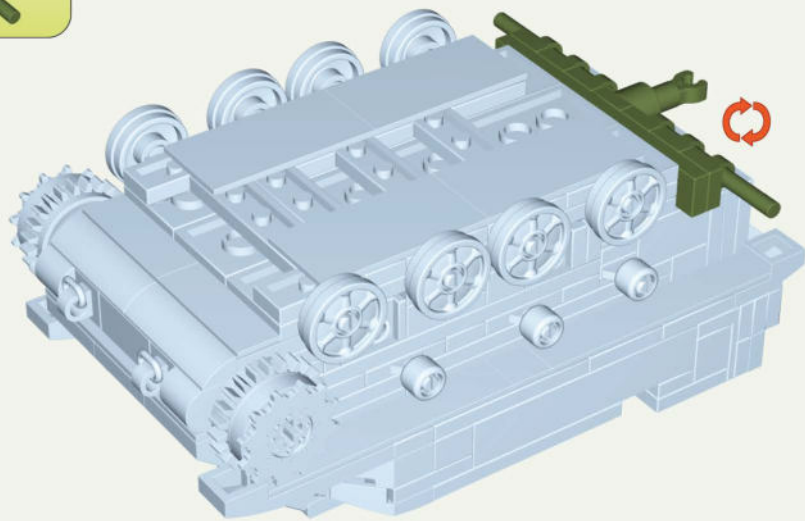
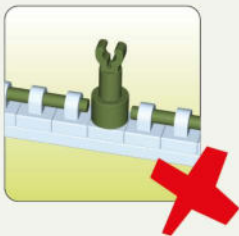
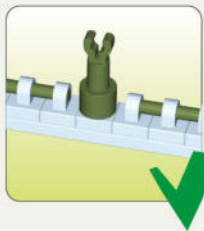
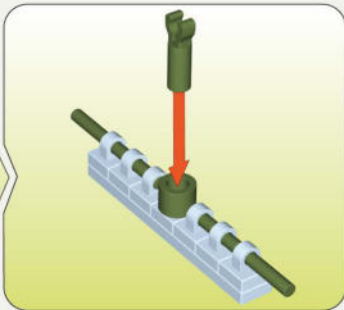
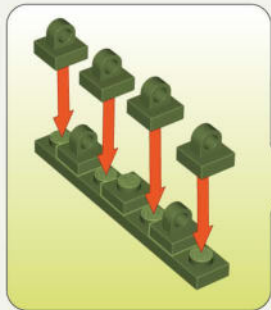

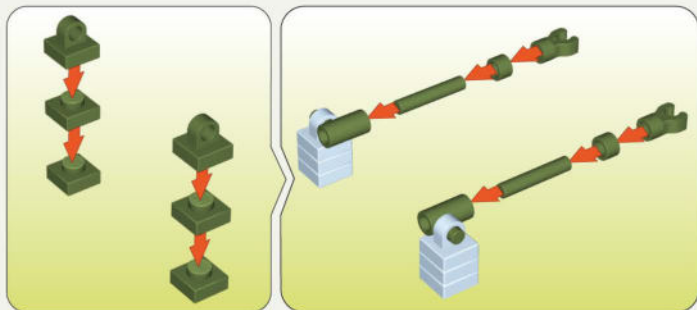
x1



x2





-  x4
-  x2
-  x2
-  x2
-  x2
-  x2
-  x2

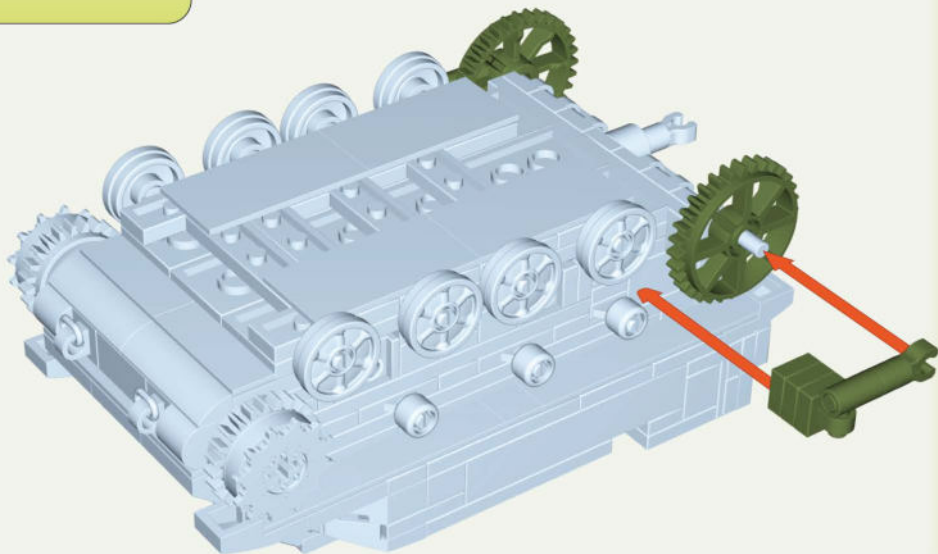
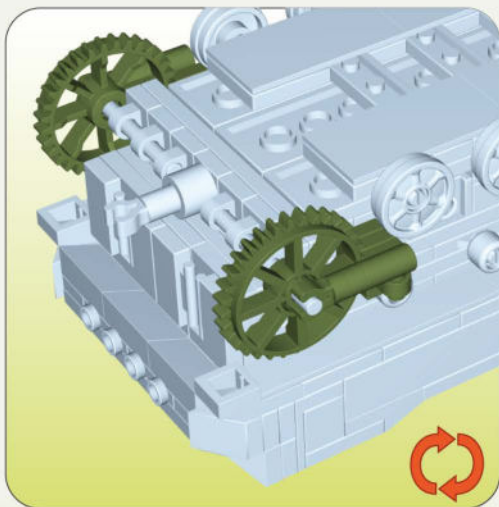

43

1:1

x4



x4

x4

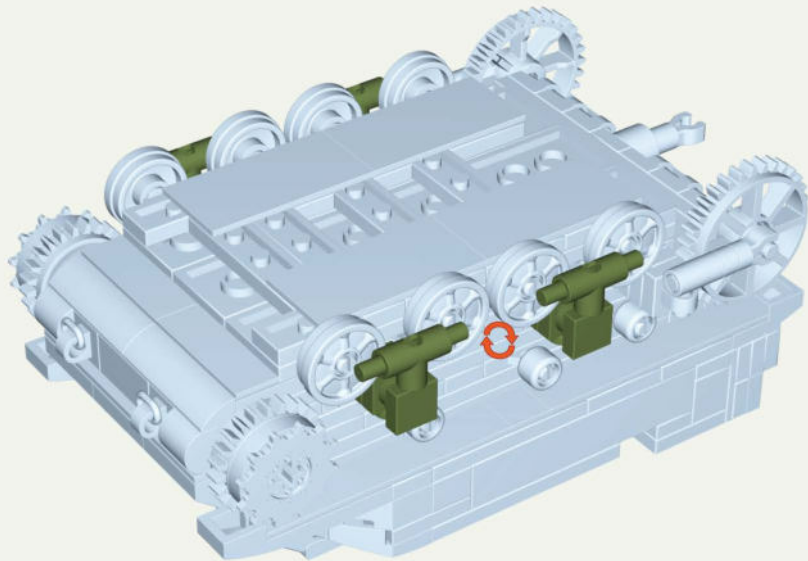
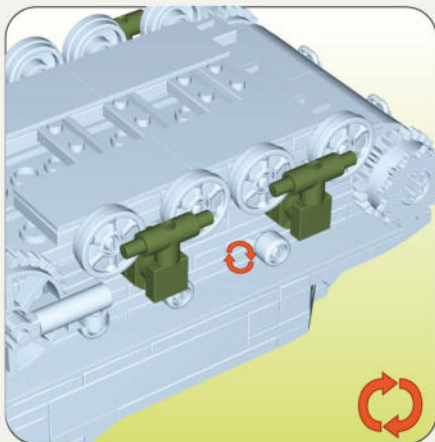
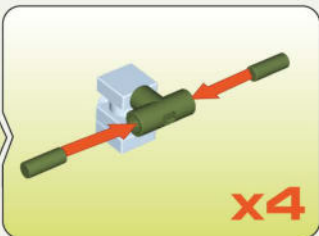
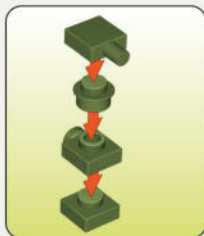

x4

x4

x8

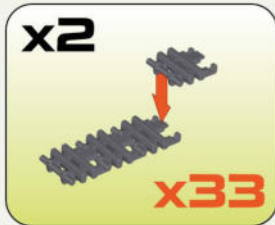
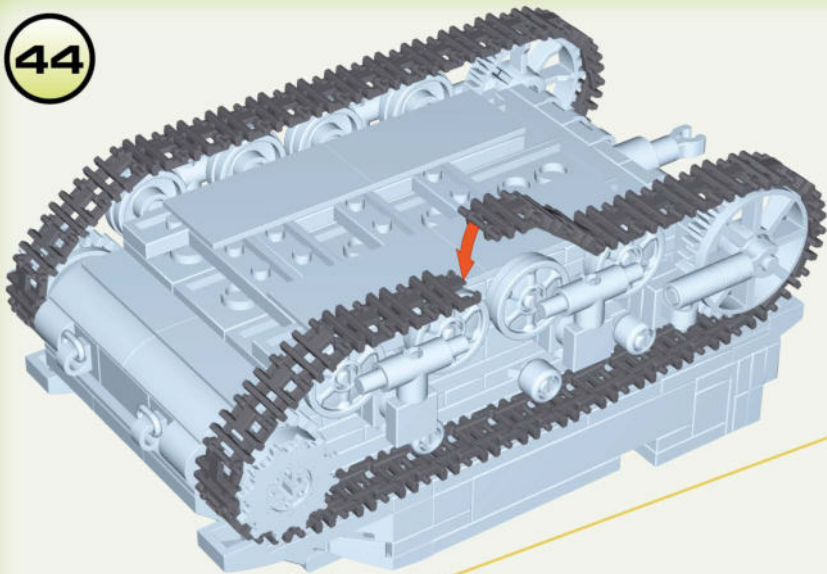

44



45



x2



x2



x1



x2

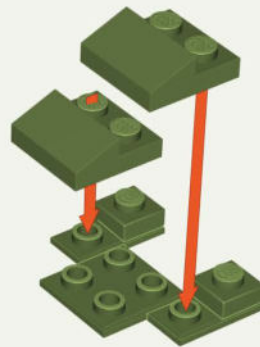

46

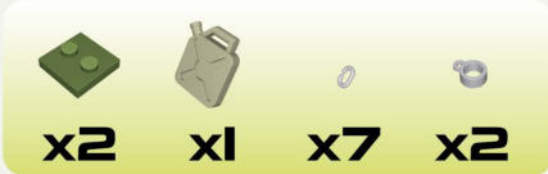
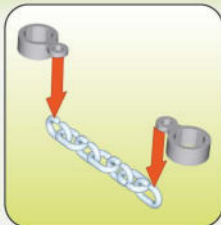
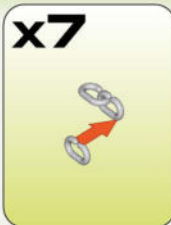
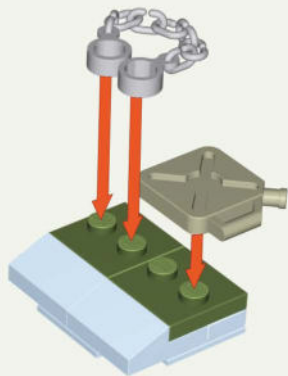

47

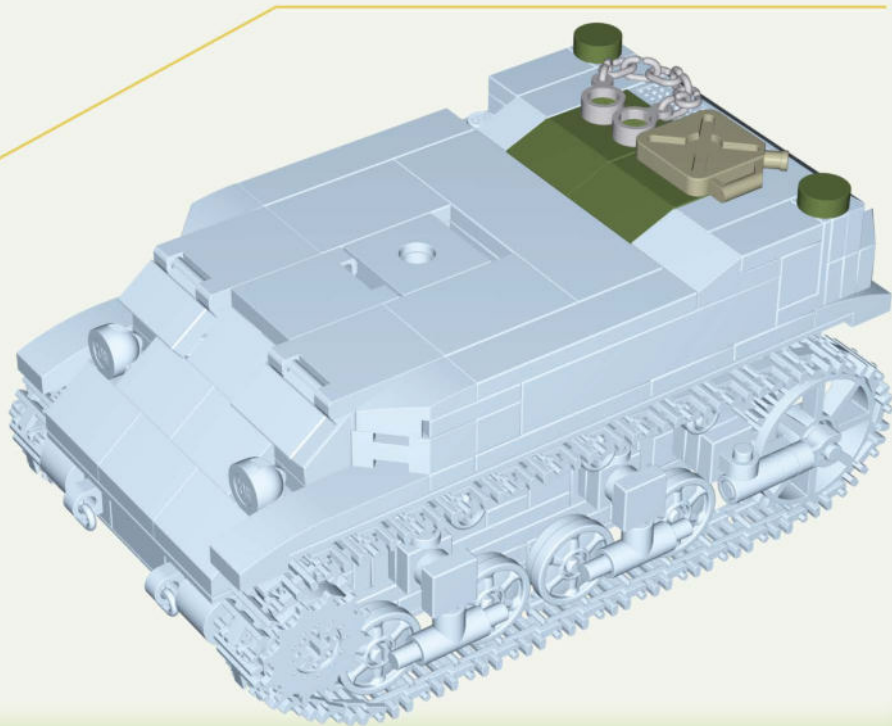

48

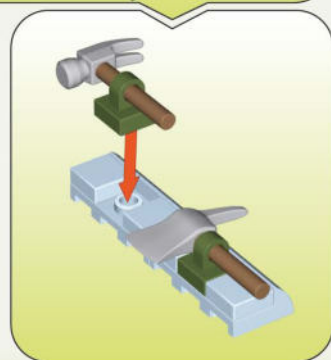
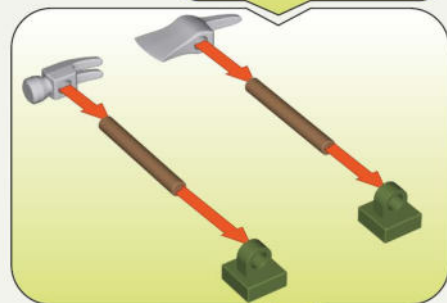
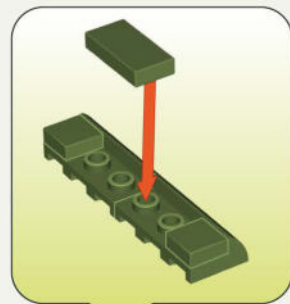
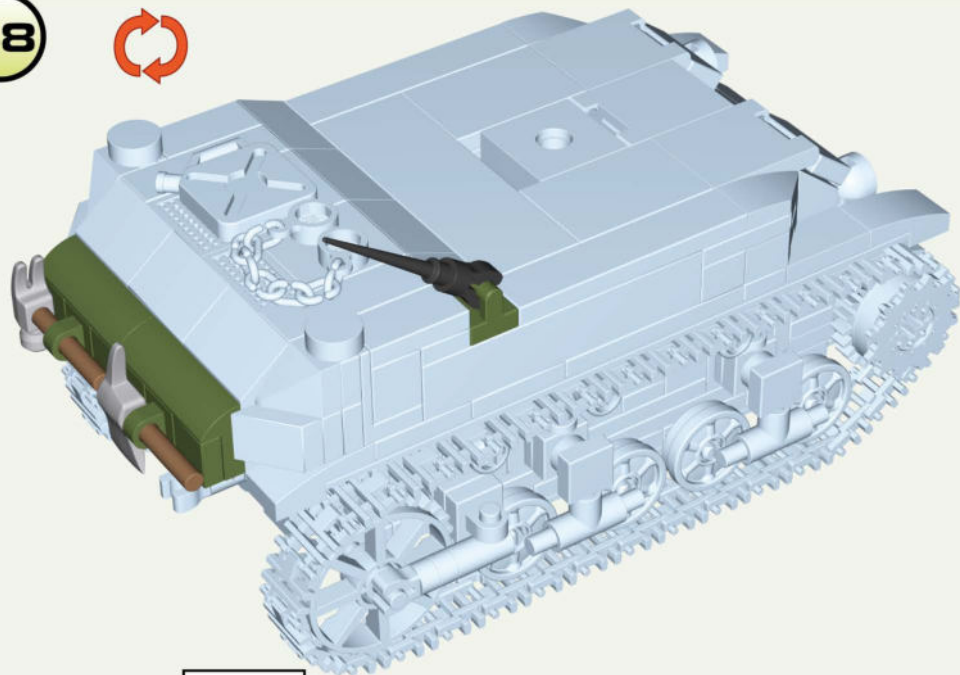

1:1

- | | | | | |
|-----------|-----------|-----------|-----------|-----------|
| | | | | |
| x2 | x2 | x1 | x2 | x2 |
| | | | | |
| x1 | x1 | x1 | x1 | x1 |



49

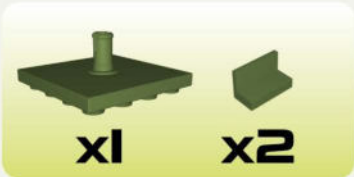
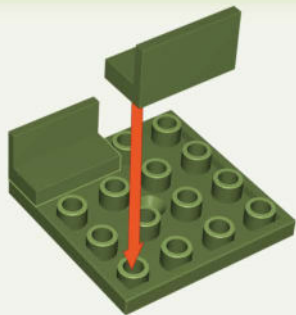

x1

x2

51

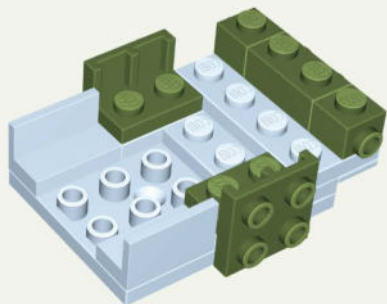

x2

x1

x2

50

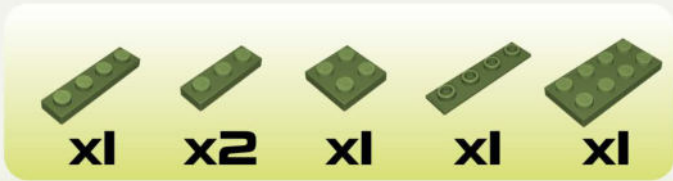
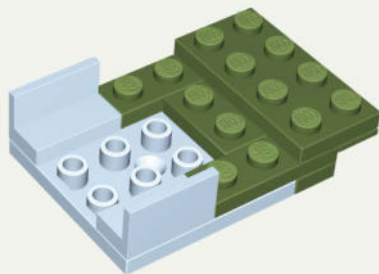
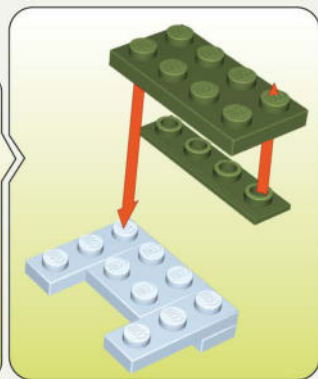
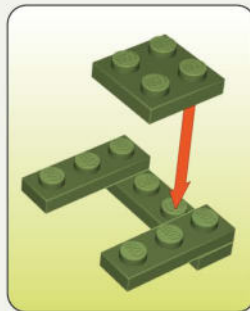

x1

x2

x1



x1

x1

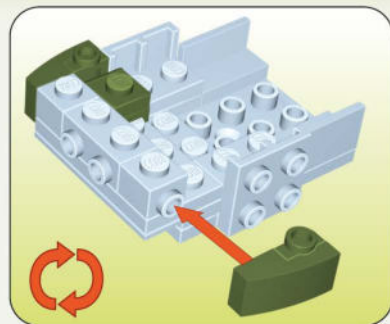
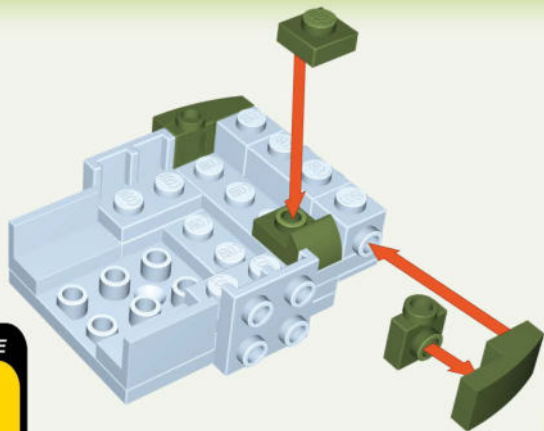
52



BE CAREFUL: NOTICE THE DIFFERENCE

C  **D** 

			
x1	x1	x2	x2

53

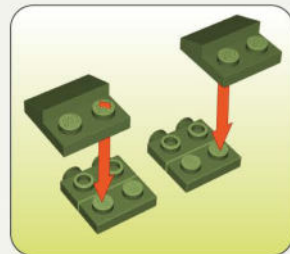
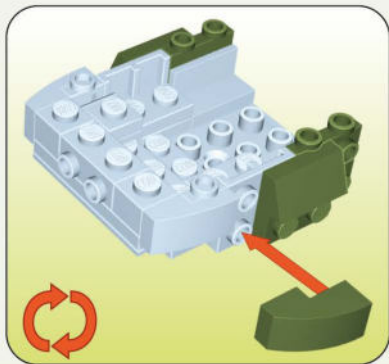
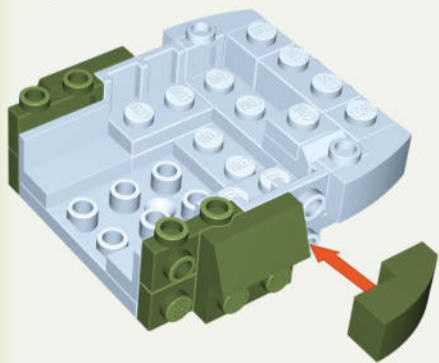

			
x2	x2	x2	x2

54

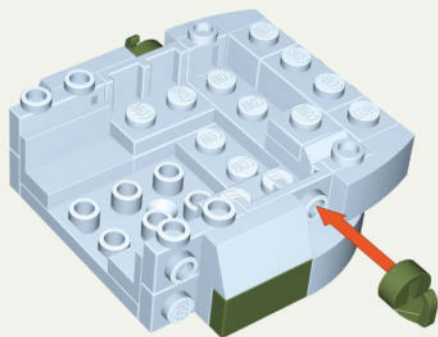

1:1



x2



x2

55

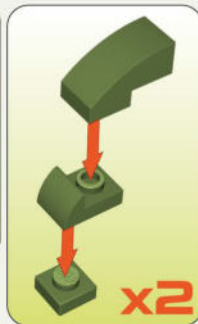
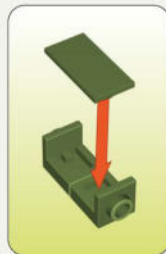
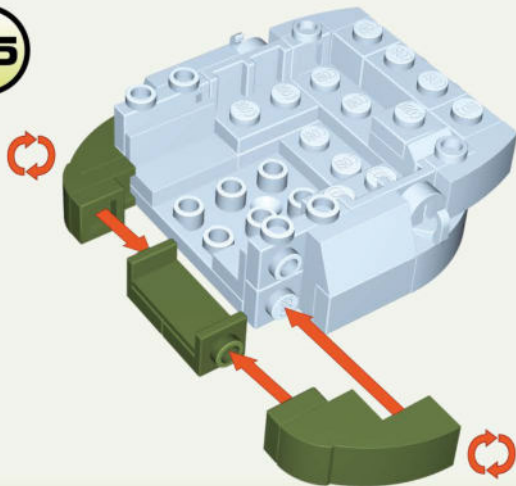

x2



x1



x2



x2



x2

®

56

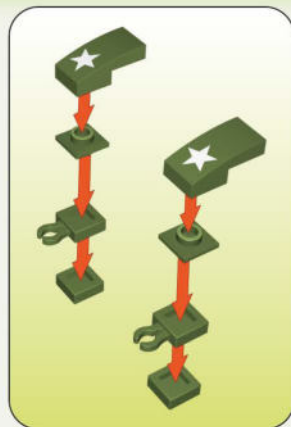
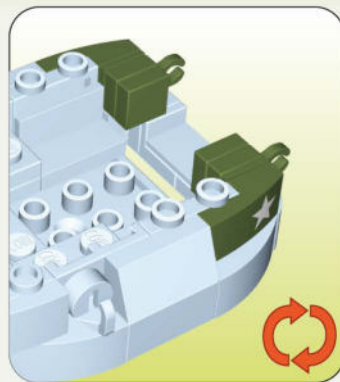
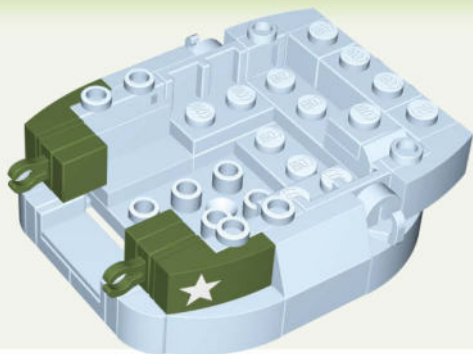

- 
x2
- 
x2
- 
x2
- 
x1
- 
x1

57

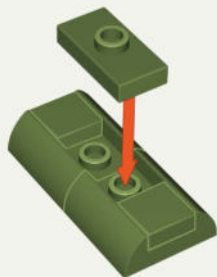

- 
x2
- 
x2
- 
x1

58

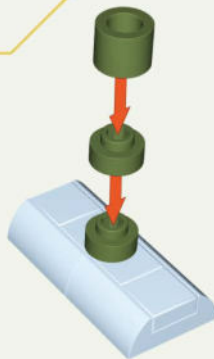

- 
x2
- 
x1

59

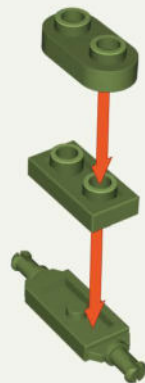

- 
x1
- 
x1
- 
x1

60

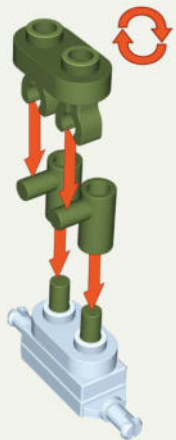

x2 x2 x2 x1

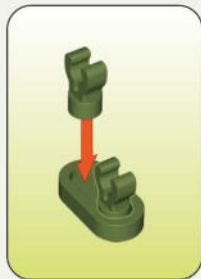

61

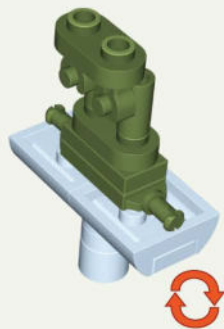



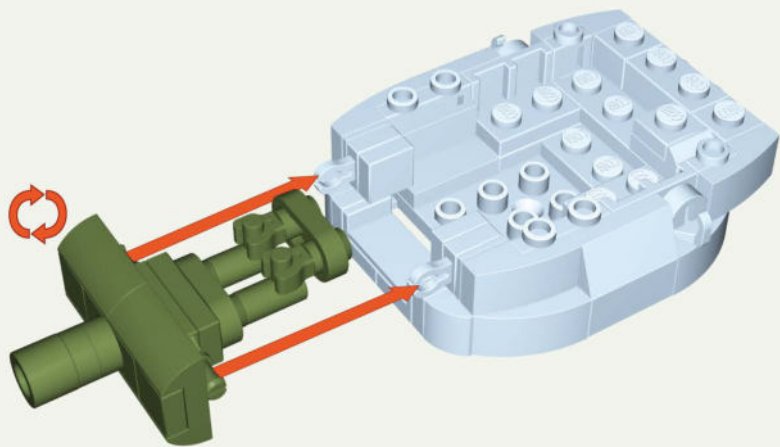

62

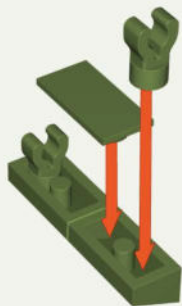
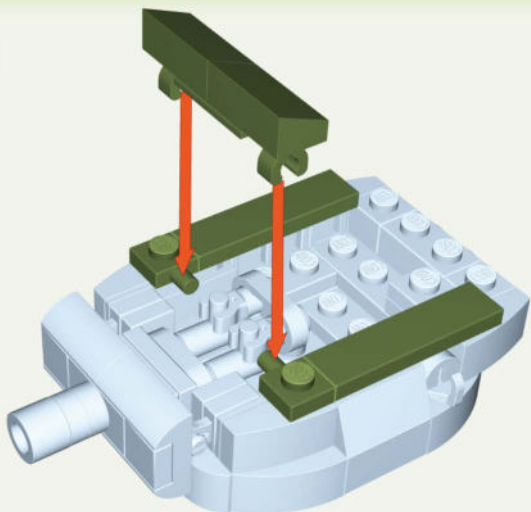

63



1:1

		
x2	x2	x2
		
x2	x1	

64

1:1

			
x1	x1	x2	x1

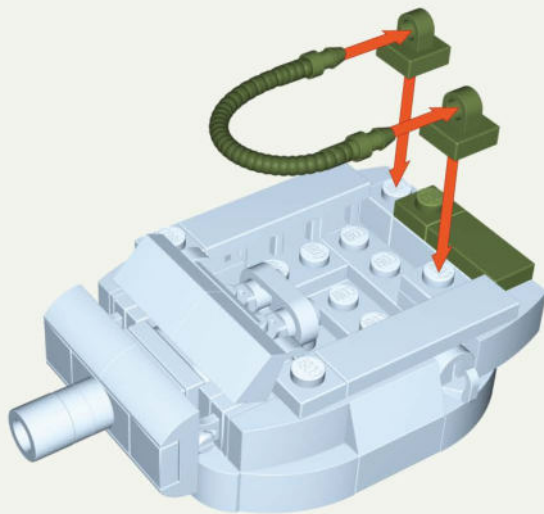

65

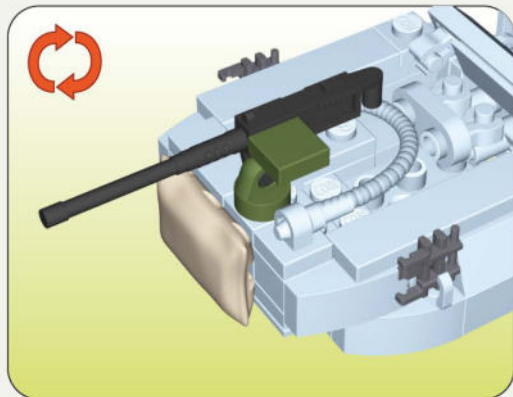
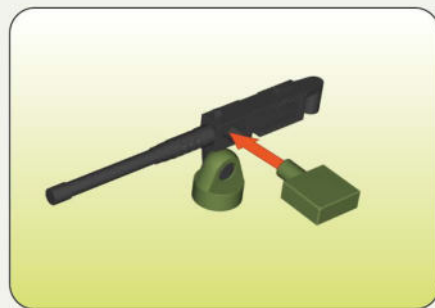
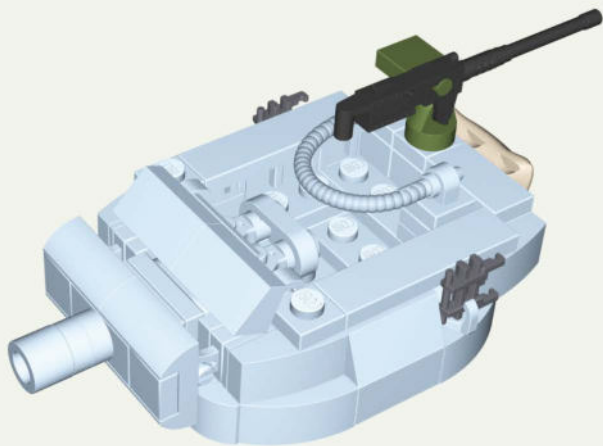

66

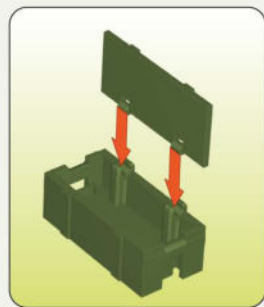
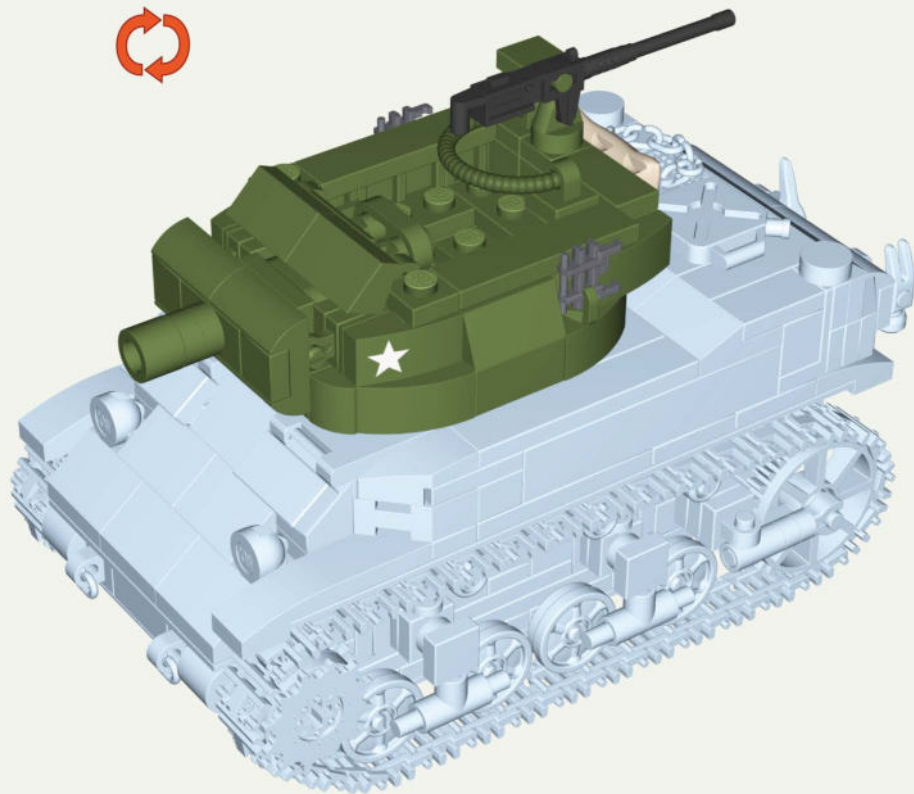

x1



x1

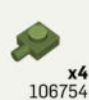
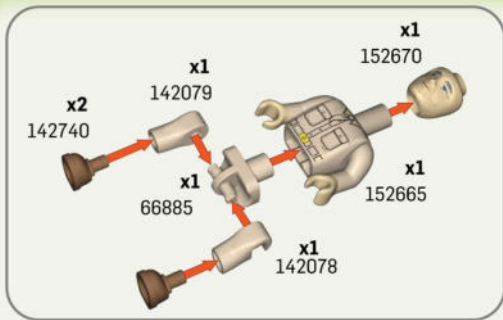



x1
152785



x1
152795



x1
152796



x4
111481



x2
132618



x6
42959



x2
107904



x2
93457



x4
115502



x6
99234



x2
109733



x5
42976



x2
64202



x3
42967



H.M.C.
M8 Scott
x1
152800



x1
128844



x2
85566



x14
43017



x3
83478



x5
128843

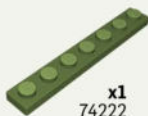

x1
74222



x1
43033



x2
43048



x4
43084



x2
43092



x2
44686



x10
43100



x6
82039



x5
111485



x4
118379



x2
77515



x7
124559



x3
151230



x1
117451



x2
141688



x2
86989



x2
152797



x2
43168



x1
111470



x4
124981



x2
43194



x1
81744

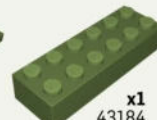

x1
43184



x1
152798

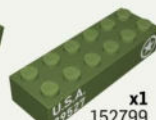

x1
152799



x1
124602



x1
43212



x3
43230



x4
109913

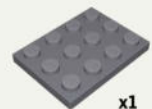

x1
89125



x1
111482



x1
54442

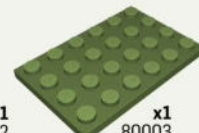

x1
80003



x1
110280



x1
152801



x8
104414

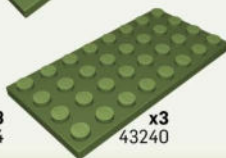

x3
43240



x4
123440



x2
152824



x8
143580



x1
104430



x1
101104





CROMWELL MK.IV
 2269























SHERMAN IC FIREFLY HYBRID
 2276

2279

H.M.C
M8 SCOTT



TABLE POINT

1.		22 cm	11.		1
2.		10 cm	12.		1
3.		-5 cm	13.		1
4.		-5 cm	14.		3
5.		+10 cm	15.		2
6.		4-6	16.		1
7.		4-6	17.		1
8.		14	18.		4
9.		2+	19.		60
10.		2	20.	 Available 1942	



2279

H.N.C N8 SCOTT



HISTORICAL COLLECTION



Sd. Kfz. 9/1 „FAMO”
+ 2281

WWW.COBI.EU

01-02279-512

For
news and
special deals

Find us on:
  [cobi.bricks](https://www.facebook.com/cobi.bricks)
[cobi.bricks](https://www.instagram.com/cobi.bricks)
 [cobi.bricks](https://www.youtube.com/cobi.bricks)
COBI SA